User manual

(RTSP Server)

Happytimesoft Technology Co., LTD

Declaration

All rights reserved. No part of this publication may be excerpted, reproduced, translated, annotated or edited, in any form or by any means, without the prior written permission of the copyright owner.

Since the product version upgrade or other reasons, this manual will subsequently be updated. Unless otherwise agreed, this manual only as a guide, this manual all statements, information, recommendations do not constitute any express or implied warranties.

www.happytimesoft.com

Table of Contents

Chapter 1 Introduction	4
Chapter 2 Key features	5
Chapter 3 Function chart	6
Chapter 4 Configuration	7
4.1 Configuration Templates	7
4.2 Configuring Node Description	10
4.2.1 System parameters	10
4.2.2 User node	12
4.2.3 Output node	12
4.2.4 Proxy node	14
4.2.5 Pusher node	15
4.2.6 Backchannel node	16
Chapter 5 Data pusher	18
Chapter 6 RTSP over HTTP	20
Chapter 7 RTSP over Websocket	23
Chapter 8 RTP Multicast	24
Chapter 9 Audio back channel	25
9.1 RTSP Require- Tag	25
9.2 Connection setup for a bi- directional connection	25
9.3 Example	28
Chapter 10 Run RTSP Server	29
Chapter 11 Multiple capture devices support	30
Chapter 12 Capture application window	31

Chapter 1 Introduction

Happytime RTSP Server is a complete RTSP server application. It can stream audio and video files in various formats.

It can also stream video from camera, living screen and application windows, stream audio from audio device.

It can stream H265, H264, MP4, MJPEG video stream and G711, G722, G726, AAC, OPUS audio stream.

These streams can be received/played by standards-compliant RTSP/RTP media clients.

It supports rtsp proxy function.

It supports audio back channel function.

It supports rtsp over http function.

It supports rtsp over https function.

It supports rtp multicast function.

Support for data pusher function.

Enjoying multimedia content from your computer can be a pleasant way for you to spend your free time. However, sometimes you might need to access it from various locations, such as a different computer or a handheld device, Happytime RTSP Server, that can help you achieve quick and efficient results.

Chapter 2 Key features

The server can transmit multiple streams concurrently

It can stream audio and video files in various formats

It can stream audio from audio device

It can stream video from camera and living screen

It can stream video from application windows

It can stream H265, H264, MP4, MJPEG video stream

It can stream G711, G722, G726, AAC, OPUS audio stream

It supports rtsp over http function

It supports rtsp over https function

It supports rtsp over websocket function

It supports rtp multicast function

It supports data pusher function

It supports RTSP proxy function, as the following:

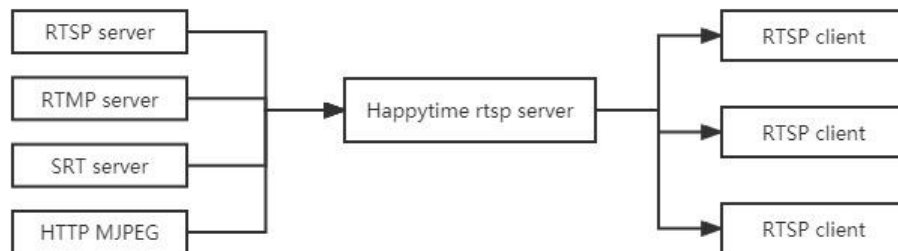

It supports audio backchannel

Happytime rtsp server complies with onvif audio backchannel specification, please refer to the link below for specification details:

<https://happytimesoft.com/knowledge/audio-back-channel.html>

It supports audio and video playback.

Happytime rtsp server complies with onvif audio and video playback specification, please refer to the link below for specification details:

<https://happytimesoft.com/knowledge/audio-video-playback.html>

Chapter 3 Function chart

The function diagram of Happytime rtsp sever is as follows:

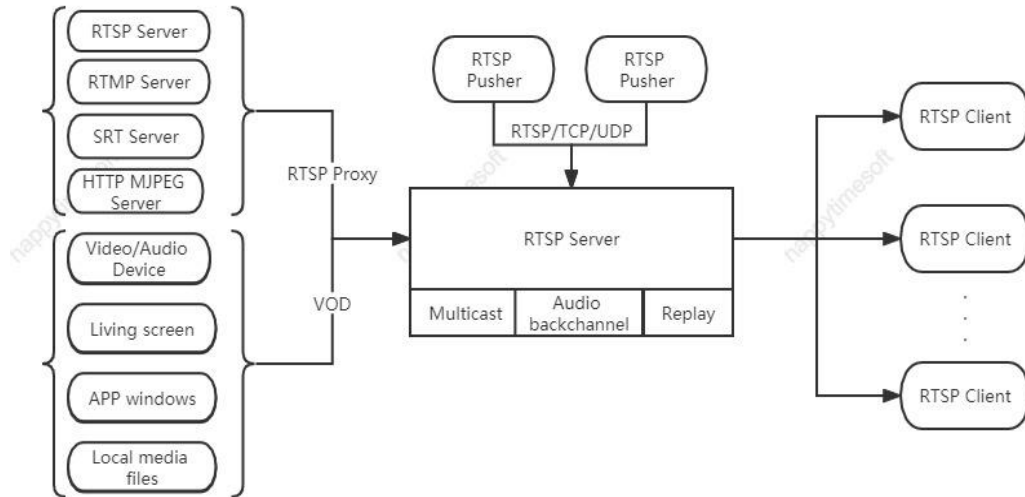

Chapter 4 Configuration

If no configuration file is specified at startup, the default configuration file `rtspserver.cfg` will be used.

4.1 Configuration Templates

```
<?xml version="1.0" encoding="utf-8"?>
<config>
  <serverip></serverip>
  <serverport>554</serverport>
  <loop_nums>1</loop_nums>
  <multicast>0</multicast>
  <udp_base_port>22000</udp_base_port>
  <metadata>1</metadata>
  <rtsp_over_http>1</rtsp_over_http>
  <http_port>8080</http_port>
  <rtsp_over_https>1</rtsp_over_https>
  <https_port>443</https_port>
  <cert_file>ssl.ca</cert_file>
  <key_file>ssl.key</key_file>
  <need_auth>0</need_auth>
  <log_enable>1</log_enable>
  <log_level>1</log_level>

  <user>
    <username>admin</username>
    <password>admin</password>
  </user>

  <output>
    <url></url>
    <video>
      <codec>H264</codec>
      <width></width>
```

```
<height></height>
<framerate></framerate>
<bitrate></bitrate>
</video>
<audio>
  <codec>G711U</codec>
  <samplerate></samplerate>
  <channels></channels>
  <bitrate></bitrate>
</audio>
</output>

<proxy>
  <suffix>proxy</suffix>
  <url></url>
  <user></user>
  <pass></pass>
  <transfer>TCP</transfer>
  <ondemand>0</ondemand>
  <output>
    <video>
      <codec>H264</codec>
      <width></width>
      <height></height>
      <framerate></framerate>
      <bitrate></bitrate>
    </video>
    <audio>
      <codec>AAC</codec>
      <samplerate></samplerate>
      <channels></channels>
      <bitrate></bitrate>
    </audio>
  </output>
```

</proxy>

<pusher>

<suffix>pusher</suffix>

<video>

<codec>H264</codec>

</video>

<audio>

<codec>G711U</codec>

<samplerate>8000</samplerate>

<channels>1</channels>

</audio>

<transfer>

<mode>RTSP</mode>

<ip></ip>

<vport>50001</vport>

<aport>50002</aport>

</transfer>

<output>

<video>

<codec></codec>

<width></width>

<height></height>

<framerate></framerate>

<bitrate></bitrate>

</video>

<audio>

<codec></codec>

<samplerate></samplerate>

<channels></channels>

<bitrate></bitrate>

</audio>

</output>

</pusher>

```
<backchannel>
  <codec>G711U</codec>
  <samplerate>8000</samplerate>
  <channels>1</channels>
</backchannel>
</config>
```

4.2 Configuring Node Description

4.2.1 System parameters

<serverip>

Specify the IP address of the RTSP server, if not specified, the rtsp server will listen to all network interfaces.

<serverport>

Specify the RTSP server port, the default is 554.

Note:On Linux systems, ports below 1024 are reserved by the system and require root privileges to be used.

<loop_nums>

When streaming media files, specify the number of loop playback, -1 means infinite loop.

<multicast>

Whether to enable rtp multicast function, 0-disable, 1-enable.

<udp_base_port>

UDP media transmission base port, RTSP over UDP mode assign UDP port on this base port.

Each rtsp session needs to assign 8 UDP ports, video RTP/RTCP port, audio RTP/RTCP port, METADATA stream RTP/RTCP port, audio back-channel RTP/RTCP port.

<metadata>

Whether to enable the meta data stream, 0-disable, 1-enable.

<rtsp_over_http>

Whether to enable rtsp over http function, 0-disable,1-enable.

<http_port>

Specify the HTTP service port for rtsp over http function.

Note:On Linux systems, ports below 1024 are reserved by the system and require root privileges to be used.

<rtsp_over_https>

Whether to enable rtsp over https function, 0-disable,1-enable.

<https_port>

Specify the HTTPS service port for rtsp over https function.

Note:On Linux systems, ports below 1024 are reserved by the system and require root privileges to be used.

<cert_file>

Specify the HTTPS service certificate file.

<key_file>

Specify the HTTPS service key file.

Note: The certificate file ssl.ca and key file ssl.key provided by default are self signed local hosts certificates, only for testing purposes (browsers may pop up untrusted certificate warnings), and cannot be used in formal deployment environments.

<need_auth>

Whether enable the user authentication function,0-disable,1-enable.

<log_enable>

Whether enable the log function,0-disable,1-enable.

<log_level>

The log level:

TRACE	0
DEBUG	1
INFO	2
WARN	3
ERROR	4
FATAL	5

4.2.2 User node

<user> : Specify the login username password, it can configure multiple nodes

<username>

The login username.

<password>

The login password.

4.2.3 Output node

<output> : Specify the audio and video output parameters, it can configure multiple nodes.

<url>

Match URL address, it can be filename, or file extension name, or special suffix. Such as:

screenlive : match living screen stream

videodevice : match camera video stream

*.mp4 : match all mp4 media file

sample.flv : match sample.flv file

If not config this node, it will match all url as the audio/video default output parameters.

The match order from top to bottom, therefore the default output configuration should be placed in the last.

<video> : Specify the video output parameters

<codec>

Specify the video stream codec, it can specify the following value:

H264 : output H264 video stream

H265 : output H265 video stream

MP4: output MP4 video stream

JPEG: output MJPEG video stream

<width>

Specify the output video width, If 0 use the original video width (live screen stream use the screen width, camera stream use the default width)

<height>

Specify the output video height, If 0 use the original video height (live screen stream use the screen height, camera stream use the default height)

<framerate>

Specify the output video framerate, If 0 use the original video framerate (live screen use the default value 15, camera stream use the default value 25)

<bitrate>

Specify the output video bit rate, if 0, automatically calculate the output bit rate, the unit is kb/s.

Note: This parameter is valid only if encoding is required (eg screenlive, videodevice) or transcoding is required.

<audio> : Specify the audio output parameters

<codec>

Specify the audio stream codec, it can specify the following value:

G711A: output G711 a-law audio stream

G711U: output G711 mu-law audio stream

G722: output G722 audio stream

G726: output G726 audio stream

AAC: output AAC audio stream

OPUS: output OPUS audio stream

<samplerate>

Specify the audio sample rate, it can specify the following values:

8000, 11025, 12000, 16000, 22050, 24000, 32000, 44100, 48000

If 0 use the original audio sample rate (audio device stream use the default value 8000)

<channels>

Specify the audio channel number, 1 is mono, 2 is stereo

If 0 use the original audio channel number (audio device stream use the default value 2)

Note : G726 only support mono.

<bitrate>

Specify the output audio bit rate, if 0, automatically calculate the output bit rate, the unit is kb/s.

Note: This parameter is valid only if encoding is required (eg screenlive, videodevice) or transcoding is required.

4.2.4 Proxy node

<proxy> : Specify the rtsp proxy parameters, it can configure multiple nodes

<suffix>

Specify the rtsp stream suffix, you can play the proxy stream from:

rtsp://[serverip]:[serverport]/[suffix]

<url>

The original rtsp/rtmp/srt/http mjpeg stream address.

<user> <pass>

Specify the original rtsp/rtmp/srt/http mjpeg stream login user and password.

<transfer>

Specify the rtsp client transfer protocol:

TCP: rtsp client uses RTP over TCP

UDP: rtsp client uses RTP over UDP

MULTICAST: rtsp client uses multicast

<ondemand>

Connect on demand, 1-Connect when needed, 0-Always keep connected

<output>

Specify the stream output parameter. If the parameter does not appear, use the parameters of the original RTSP/RTMP/SRT/HTTP MJPEG stream. If it appears and the configured parameters are inconsistent with the parameters of the original RTSP/RTMP/SRT/HTTP MJPEG stream, then the transcode output is performed.

The child nodes under this node are consistent with the meaning of the <output> node.

4.2.5 Pusher node

<pusher> : Specify the data pusher parameters, it can configure multiple nodes

<suffix>

Specify the rtsp stream suffix, you can play the pusher stream from:

rtsp://[serverip]:[serverport]/[suffix]

<video> : Specify the the input video data parameters

<codec>

Specify the video codec, it can specify the following value:

H264 : H264 video stream

H265 : H265 video stream

JPEG: MJPEG video stream

MP4: MPEG4 video stream

<audio> : Specify the input audio data parameters

<codec>

Specify the audio codec, it can specify the following value:

G711A: G711 a-law audio stream

G711U: G711 mu-law audio stream

G722: G722 audio stream

G726: G726 audio stream

OPUS: OPUS audio stream

AAC: AAC audio stream

<samplerate>

Specify the audio sample rate, it can specify the following values:

8000, 11025, 12000, 16000, 22050, 24000, 32000, 44100, 48000

<channels>

Specify the audio channel number, 1 is mono, 2 is stereo

Note : G726 only support mono.

<transfer>: Specify the data transfer parameters

<mode>: Specify the data transfer protocol, it can specify the following value:

TCP: Use TCP connection to transfer the data

UDP: Use UDP connection to transfer the data

RTSP: Use RTSP connection to transfer the data. It supports standard rtsp push, such as FFmpeg rtsp push.

<ip>: Specified data receiving IP address, if there is no configuration, the default IP address is used.

<vport>: Specify the video data receiving port

<aport>: Specify the audio data receiving port

Note : <ip>, <vport>, <aport> these 3 parameters are valid when <mode> is TCP or UDP.

<output>

Specify the stream output parameter. If the parameter does not appear, use the parameters of the original pusher stream. If it appears and the configured parameters are inconsistent with the parameters of the original pusher stream, then the transcode output is performed.

The child nodes under this node are consistent with the meaning of the <output> node.

4.2.6 Backchannel node

<backchannel> : specify the audio back channel parameters

<codec>

Specify the audio back channel stream codec, it can specify the following value:

G711A: G711 a-law audio stream

G711U: G711 mu-law audio stream

G722: G726 audio stream

G726: G726 audio stream

OPUS: OPUS audio stream

AAC: AAC audio stream

<samplerate>

Specify the audio back channel sample rate, it can specify the following values:

8000, 11025, 12000, 16000, 22050, 24000, 32000, 44100, 48000

If 0 use the default value 8000

<channels>

Specify the audio channel number, 1 is mono, 2 is stereo

If 0 use the default value 1

Note : G726 only support mono.

Chapter 5 Data pusher

Data push means that RTSP server receives external data sources and then sends them out as RTSP streams.

The data pusher supports TCP, UDP and RTSP mode.

Audio and video data are packaged and sent in RTP format.

If it is TCP mode, you need to add 4 bytes in front of the RTP header, as the following:

```
typedef struct
{
    uint32  magic      : 8;
    uint32  channel   : 8;
    uint32  rtp_len   : 16;
} RILF;
```

magic: 0x24

channel: 0

rtp_len: the RTP load length, including RTP header

Note: If you use TCP or UDP mode data push, you need to add <pusher> tag in the rtsp server configuration file, specify the push audio and video parameters and push port, etc.

If you use RTSP mode to push data, no configuration is required. The url suffix of the pushed RTSP address can be any legal string.

If it is RTSP mode, it supports standard RTSP push stream, such as FFmpeg rtsp push.

FFmpeg rtsp over UDP:

```
ffmpeg -re -i test.mp4 -vcodec libx264 -acodec copy -preset ultrafast -f rtsp rtsp://[serverip]:[serverport]/pusher
```

FFmpeg rtsp over TCP:

```
ffmpeg -re -i test.mp4 -vcodec libx264 -acodec copy -preset ultrafast -f rtsp -rtsp_transport tcp rtsp://[serverip]:[serverport]/pusher
```

After the above ffmpeg rtsp push command is executed, you can use the following address to play the rtsp stream:

rtsp://[serverip]:[serverport]/pusher

Chapter 6 RTSP over HTTP

The key of RTSP over HTTP is to allow RTSP packets to communicate via HTTP port.

We know that the standard port of RTSP is 554, but due to various security policy configurations such as firewalls, there may be restrictions when the client accesses port 554, which prevents the normal transmission of RTSP packets.

But the HTTP port (port 80) is generally open, so there is the idea of letting RTSP packets pass through port 80, namely RTSP over HTTP.

The details of RTSP over HTTP are as follows:

First, the client opens two socket connect to the rtsp server HTTP ports. We call these two sockets "data socket" and "command socket".

Step 1. The client sends an HTTP GET command through the "data socket" to request an RTSP connection.

Step 2. The server responds to the HTTP GET command through the "data socket" and responds with success/failure.

Step 3. The client creates a "command socket" and sends an HTTP POST command through the "command socket" to establish an RTSP session.

At this point, the auxiliary function of HTTP is completed, and the server does not return the client's HTTP POST command. Next is the standard process of RTSP on the HTTP port, but it needs to be completed through two sockets. The "command socket" is only responsible for sending, and the "data socket" is only responsible for receiving.

Step 4. The client sends RTSP commands (BASE64 encoding) through the "command socket".

Step 5. The server responds to the RTSP command (in plain text) through the "data socket".

Step 6. Repeat Step4-Step5 until the client sends the RTSP PLAY command and the server responds to the RTSP PLAY command.

Step 7. The server transmits audio and video data to the client through the "data socket"

After the data exchange is complete...

Step 8. The client sends the RTSP TEARDOWN command (BASE64 encoding and) through the "command socket"

Step 9. The server responds to the RTSP TEARDOWN command (in plain text) through

the "data socket".

Step 10. Close the two sockets.

VLC supports RTSP over HTTP, the settings as the follows:

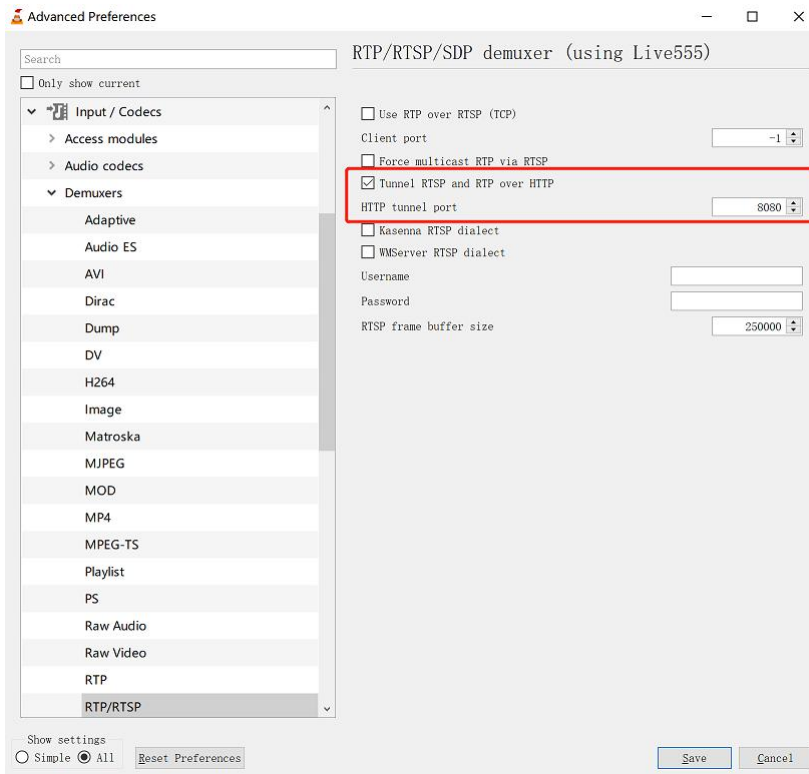

Happytime rtsp client

(<http://happytimesoft.com/products/rtsp-client/index.html>) supports RTSP over HTTP, The setting as the following:

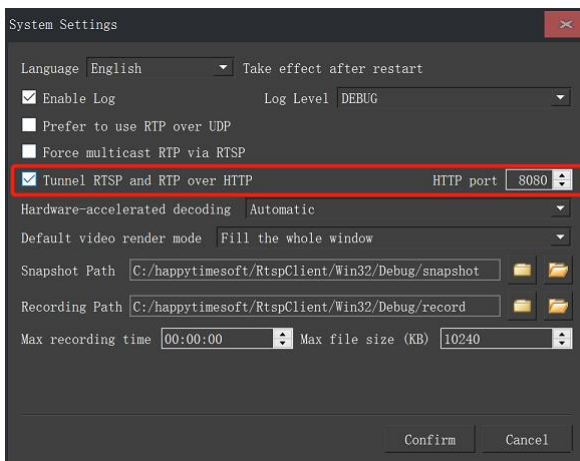

Happytime rtsp client also supports rtsp streams starting with http:// or https://.

If it starts with http://, it is considered to be a rtsp over http stream.

If it starts with https://, it is considered to be a rtsp over https stream.

Chapter 7 RTSP over WebSocket

First establish an HTTP connection, and then upgrade to the websocket protocol, RTSP over websocket protocol upgrade process:

C-->S:

GET /websocket HTTP/1.1 Host: 192.168.3.27

Upgrade: websocket Connection: Upgrade

Sec-WebSocket-Key: KSO+hOFs1q5SkEnx8bvp6w== Origin: http://192.168.3.27

Sec-WebSocket-Protocol: rtsp.onvif.org Sec-WebSocket-Version: 13

S-->C:

HTTP/1.1 101 Switching Protocols Upgrade: websocket

Connection: Upgrade

Sec-WebSocket-Accept: G/cEt4HtsYEnP0MnSVkKRk459gM= Sec-WebSocket-Protocol:
rtsp.onvif.org

Sec-WebSocket-Version: 13

After the protocol upgrade is successful, perform normal rtsp protocol exchange, and send and receive data through websocket connection.

Chapter 8 RTP Multicast

To enable the rtp multicast function, it need to specify the <multicast> to 1 in the configuration file.

The rtsp server does not support the configuration of multicast addresses.

Different rtsp stream addresses use multicast, randomly assigned multicast addresses starting with 232.

Different rtsp sessions use rtp multicast to play the same rtsp stream, using the same multicast address. Only the first rtsp session sends audio and video data, and subsequent sessions refer to the first rtsp session.

The rtp multicast stream address is the same as the other rtsp stream address.

Use VLC to test rtp multicast, use the following settings:

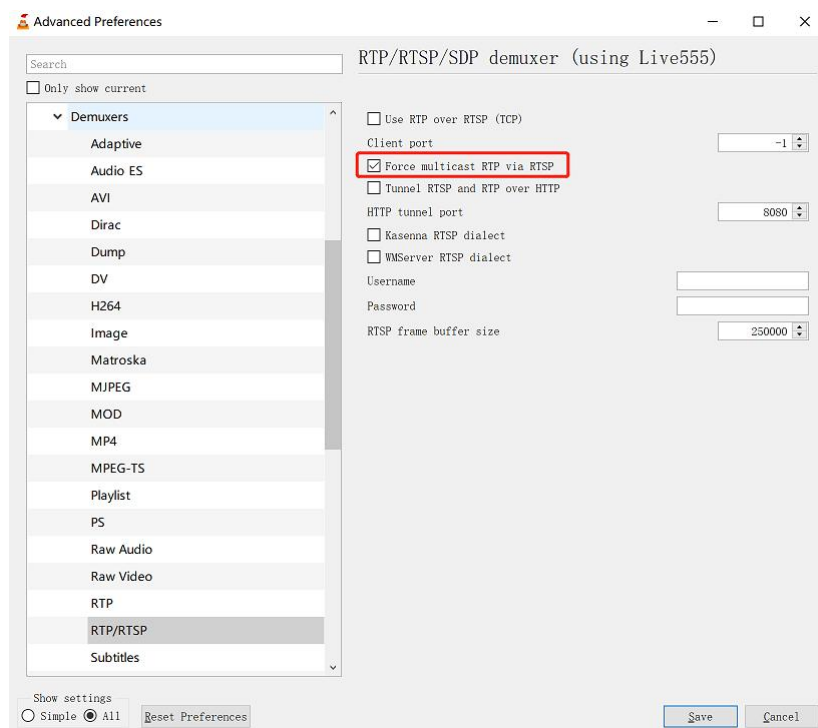

Chapter 9 Audio back channel

The backchannel connection handling is done using RTSP [RFC 2326]. Therefore a mechanism is introduced which indicates that a client wants to built up a backchannel connection. RTSP provides feature-tags to deal with such functionality additions. A device that supports bi-directional connections (e.g audio or metadata connections) shall support the introduced RTSP extensions.

9.1 RTSP Require- Tag

The RTSP standard [RFC 2326] can be extended by using additional headers objects. For that purpose a Require tag is introduced to handle special functionality additions (see [RFC 2326], 1.5 Extending Rtp and 12.32 Require).

The Require-tag is used to determine the support of this feature. This header shall be included in any request where the server is required to understand that feature to correctly perform the request.

A device that supports backchannel and signals Audio output support via the AudioOutputs capability shall understand the backchannel tag:

`www.onvif.org/ver20/backchannel`

An RTSP client that wants to built up an RTSP connection with a data backchannel shall include the Require header in its requests.

9.2 Connection setup for a bi- directional connection

A client shall include the feature tag in it's DESCRIBE request to indicate that a bidirectional data connection shall be established.

A server that understands this Require tag shall include an additional media stream in its SDP file as configured in its Media Profile.

An RTSP server that does not understand the backchannel feature tag or does not support bidirectional data connections shall respond with an error code 551 Option not supported according to the RTSP standard. The client can then try to establish an RTSP connection without backchannel.

A SDP file is used to describe the session. To indicated the direction of the media data the server shall include the a=sendonly in each media section representing media being sent from the client to the server and a=recvonly attributes in each media section representing media being sent from the server to the client.

The server shall list all supported decoding codecs as own media section and

the client chooses which one is used. The payload type and the encoded bitstream shall be matched with one of the a=rtpmap fields provided by the server so that the server can properly determine the audio decoder.

Example 1: Server without backchannel support:

```
Client - Server:      DESCRIBE rtsp://192.168.0.1 RTSP/1.0
                      Cseq: 1
                      User-Agent: ONVIF Rtsp client
                      Accept: application/sdp
                      Require: www.onvif.org/ver20/backchannel

Server - Client:      RTSP/1.0 551 Option not supported
                      Cseq: 1
                      Unsupported: www.onvif.org/ver20/backchannel
```

Example 2: Server with Onvif backchannel support:

```
Client - Server:      DESCRIBE rtsp://192.168.0.1 RTSP/1.0
                      Cseq: 1
                      User-Agent: ONVIF Rtsp client
                      Accept: application/sdp
                      Require: www.onvif.org/ver20/backchannel

Server - Client:      RTSP/1.0 200 OK
                      Cseq: 1
                      Content-Type: application/sdp
                      Content-Length: xxx

                      v=0
                      o= 2890842807 IN IP4 192.168.0.1
                      s=RTSP Session with audiobackchannel
                      m=video 0 RTP/AVP 26
                      a=control:rtsp://192.168.0.1/video
                      a=recvonly
                      m=audio 0 RTP/AVP 0
                      a=control:rtsp://192.168.0.1/audio
                      a=recvonly
                      m=audio 0 RTP/AVP 0
                      a=control:rtsp://192.168.0.1/audioback
                      a=rtpmap:0 PCMU/8000
                      a=sendonly
```

This SDP file completely describes the RTSP session. The Server gives the client its control URLs to setup the streams.

In the next step the client can setup the sessions:

```
Client - Server:      SETUP rtsp://192.168.0.1/video RTSP/1.0
                      Cseq: 2
                      Transport: RTP/AVP;unicast;client_port=4588-4589

Server - Client:     RTSP/1.0 200 OK
                      Cseq: 2
                      Session: 123124;timeout=60
                      Transport:RTP/AVP;unicast;client_port=4588-4589;
                      server_port=6256-6257

Client - Server:     SETUP rtsp://192.168.0.1/audio RTSP/1.0
                      Cseq: 3
                      Session: 123124
                      Transport: RTP/AVP;unicast;client_port=4578-4579

Server - Client:     RTSP/1.0 200 OK
                      Cseq: 3
                      Session: 123124;timeout=60
                      Transport:RTP/AVP;unicast;client_port=4578-4579;
                      server_port=6276-6277

Client - Server:     SETUP rtsp://192.168.0.1/audioback RTSP/1.0
                      Cseq: 4
                      Session: 123124
                      Transport: RTP/AVP;unicast;client_port=6296-6297
                      Require: www.onvif.org/ver20/backchannel

Server - Client:     RTSP/1.0 200 OK
                      Cseq: 4
                      Session: 123124;timeout=60
                      Transport:RTP/AVP;unicast;client_port=6296-6297;
                      server_port=2346-2347
```

The third setup request establishes the audio backchannel connection.

In the next step the client starts the session by sending a PLAY request.

```
Client - Server:      PLAY rtsp://192.168.0.1 RTSP/1.0
                      Cseq: 5
                      Session: 123124
                      Require: www.onvif.org/ver20/backchannel

Server - Client:     RTSP/1.0 200 OK
                      Cseq: 5
                      Session: 123124;timeout=60
```

After receiving the OK response to the PLAY request the client MAY start sending audio data to the server. It shall not start sending data to the server before it has received the response.

The Require-header indicates that a special interpretation of the PLAY command is necessary. The command covers both starting of the video and audio stream from NVT to the client and starting the audio connection from client to server.

To terminate the session the client sends a TEARDOWN request.

```
Client - NVT:         TEARDOWN rtsp://192.168.0.1 RTSP/1.0
                      Cseq: 6
                      Session: 123124
                      Require: www.onvif.org/ver20/backchannel

NVT - Client:        RTSP/1.0 200 OK
                      Cseq: 6
                      Session: 123124
```

9.3 Example

Server with Onvif backchannel support (with multiple decoding capability)

If a device supports multiple audio decoders as backchannel, it can signal such capability by listing multiple `a=rtpmap` fields illustrated as follows.

```
Client - Server:      DESCRIBE rtsp://192.168.0.1 RTSP/1.0
                    Cseq: 1
                    User-Agent: ONVIF Rtsp client
                    Accept: application/sdp
                    Require: www.onvif.org/ver20/backchannel

Server - Client:     RTSP/1.0 200 OK
                    Cseq: 1
                    Content-Type: application/sdp
                    Content-Length: xxx

                    v=0
                    o= 2890842807 IN IP4 192.168.0.1
                    s=RTSP Session with audiobackchannel
                    m=video 0 RTP/AVP 26
                    a=control:rtsp://192.168.0.1/video
                    a=recvonly
                    m=audio 0 RTP/AVP 0
                    a=control:rtsp://192.168.0.1/audio
                    a=recvonly
                    m=audio 0 RTP/AVP 0 97 98 99 100
                    a=control:rtsp://192.168.0.1/audioback
                    a=rtpmap:0 PCMU/8000
                    a=rtpmap:97 G726-16/8000
                    a=rtpmap:98 G726-24/8000
                    a=rtpmap:99 G726-32/8000
                    a=rtpmap:100 G726-40/8000
                    a=sendonly
```

Chapter 10 Run RTSP Server

The server is a console application.

Windows: to run the server, simply type "rtspserver".

Linux: to run the server, type "./start.sh", on linux platform, rtsp server run as daemon by default.

rtsp server supports the following command line options:

`-c config` specify the configuration file

`-c` option specifies the configuration file, if not specified, the default configuration `rtspserver.cfg` is used.

`-l [device|videodevice|audiodevice|window]`

`-l device` list available video and audio capture device

`-l videodevice` list available video capture device

`-l audiodevice` list available audio capture device

`-l window` list available application window

Below is sample output of `-l device`:

```
rtspserver -l device
```

```
Available video capture device :
```

```
index : 0, name : FaceTime HD Camera (Built-in)
```

```
Available audio capture device :
```

```
index : 0, name : Headset Microphone (Apple Audio Device)
```

```
index : 1, name : Internal Digital Microphone (Apple Audio Device)
```

Note : The demo version has the following limitations:

Maximum support four concurrent sessions.

Chapter 11 Multiple capture devices support

If your system have multiple audio capture device, you can use

```
rtsp://[serverip]:[serverport]/audiodeviceN
```

The N to specify the audio capture device index, start from 0, such as:

```
rtsp://192.168.0.100/audiodevice ; stream audio from the first audio device
```

```
rtsp://192.168.0.100/audiodevice1 ; stream audio from the second audio device
```

If your system have multiple video capture device, you can use

```
rtsp://[serverip]:[serverport]/videodeviceN
```

The N to specify the video capture device index, start from 0, such as:

```
rtsp://192.168.0.100/videodevice ; stream video from the first video device
```

```
rtsp://192.168.0.100/videodevice1 ; stream video from the second video device
```

If your system have multiple monitors, you can use

```
rtsp://[serverip]:[serverport]/screenliveN
```

The N to specify the monitor index, start from 0, such as:

```
rtsp://192.168.0.100/screenlive ; stream living screen from the first monitor
```

```
rtsp://192.168.0.100/screenlive1 ; stream living screen from the second monitor
```

The audio index or video index represents which device can run the following command to view:

```
rtspserver -l device
```

videodevice or audiodevice can also specify the device name, such as :

```
rtsp://[serverip]:[serverport]/videodevice=testvideo
```

Run the ***rtspserver -l device*** command to get the device name.

Note that there can be no spaces in the device name, if the device name contains spaces, you need to use %20 instead of spaces.

If the device name is “FaceTime HD Camera”, the rtsp stream address is:

```
rtsp://[serverip]:[serverport]/videodevice=FaceTime%20HD%20Camera
```

Chapter 12 Capture application window

The rtsp server supports capturing application windows, you can use the following command to list valid application windows:

```
rtspserver -l window
```

Below is a sample output of the command

Available window name :

```
C:\Windows\system32\cmd.exe - RtspServer.exe -l window  
user manual.doc - WPS Office  
Rtsp-server Project - Source Insight - [Main.cpp]  
RtspServer
```

You can use the following url to capture the specified application window:

```
rtsp://[serverip]:[serverport]/window=[window title]
```

Note : window title case insensitive

Such as :

```
rtsp://[serverip]:[serverport]/window=rtspserver
```

Note that there can be no spaces in the window title, if the window title contains spaces, you need to use %20 instead of spaces. Such as:

```
rtsp://[serverip]:[serverport]/window=user%20manual.doc%20-%20WPS%20office
```